



HONG HUA AMERICA, LLC

HHF-1000 Mud Pump



(832) 448.8100

www.hh-america.com



HONGHUA Group (HH) HHF series mud pump is tough and field-proven, is specifically equipped to meet almost any customer requirement.

We have provided more than 1000 sets in the world-wide. This is backed by our warranty and field support program. And the HHF-1000 pump is one of the most acceptable and developed mud pump.

HHF-1000 mud pump is a kind of F series, triplex single-acting piston mud pump. HHF-1000 mud pump is made of high quality material, according to API 7K specification.

Specification

- | | |
|---------------------------------------|---|
| ▪ Rated input power | 1000HP (746 KW) |
| ▪ Rated Stroke | 140 SPM |
| ▪ Max. liner Di a. | 6 ¾" (170 mm) |
| ▪ Rated Stroke distance | 10" (254 mm) |
| ▪ Gear Ratio: | 4.207: 1 |
| ▪ Suction pipe size: | 12" (304.8mm), Flanged |
| ▪ Discharge pipe size: | API 5 1/8" (130mm) Flanged, 5000psi |
| ▪ Valve chamber size: | API 6 # |
| ▪ Lubrication: | Forced and splash |
| ▪ Discharge flow and pressure: | please reference table 1 and table 2 |





Table 1: Pressure parameter for mud pump HHF-1000

Diameter of Liner	6 ¾"	6 ½"	6"	5 ½"	5 "	4 ½"
Rated pressure	2730 psi 16.3 MPa	2558 psi 17.6 MPa	3000 psi 20.7 MPa	3572 psi 24.6 MPa	4322 psi 29.8 MPa	5000 psi 34.5 MPa

Table 2: Discharge parameter for mud pump HHF-1000

Stroke (spm)	Rated power		Discharge capacity GPM					
	kW	HP	6 ¾"	6 ½"	6"	5 ½"	5 "	4 ½"
150	799	1071	697	646	551	463	382	310
140*	746*	1000*	651	603	514	432	357	289
130	692	928	604	560	477	401	331	269
120	639	857	558	517	441	370	306	248
110	585	785	511	474	404	339	280	227
100	532	714	465	431	367	309	255	207
90	479	642	418	388	330	278	229	186
1			4.65	4.31	3.67	3.09	2.55	2.07

Notes:

1. Calculated as per volumetric efficiency (100%) and mechanical efficiency (90%).
2. * shows rated stroke numbers while operating.





Dimension

- **Transport dimension**

Length

13'-4" (4065mm)

Width

7'- 8 ½" (2351mm)

Height

6' – ¼" (1834mm)

- **Weight (without damper)**

40443 lbs (18345 kg)

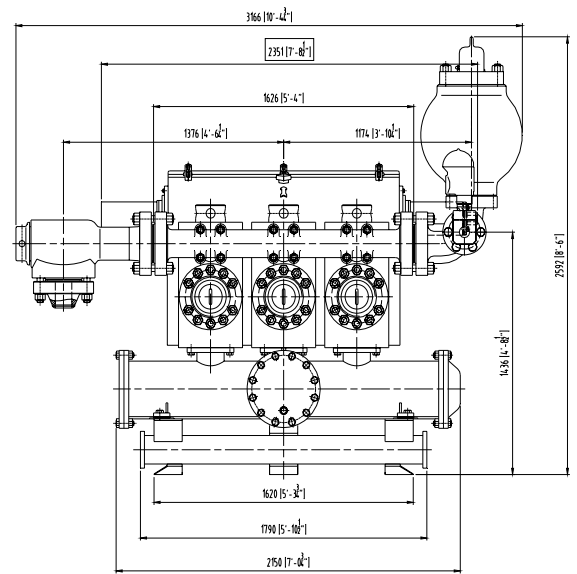
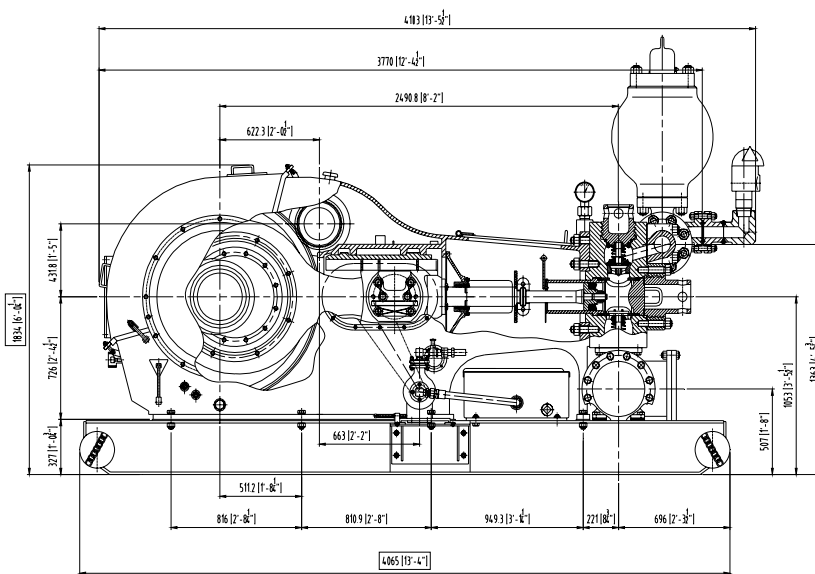



Equipment scope

- Mud pump with a liner
 - Dampener and safety valve
 - Completed with spare parts and special tools and fits
-
- We also maintain spare parts for you all requirements.

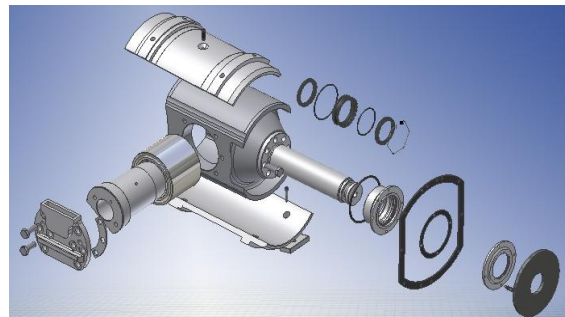

Please contact us if you need more information!

Honghua, America, LLC

8300 McHard Road, Houston, TX 77053

Tel : (832) 448.8100

Fax : (832) 448.8101

E-mail: sales@hh-america.com

Website: www.hh-america.com

