

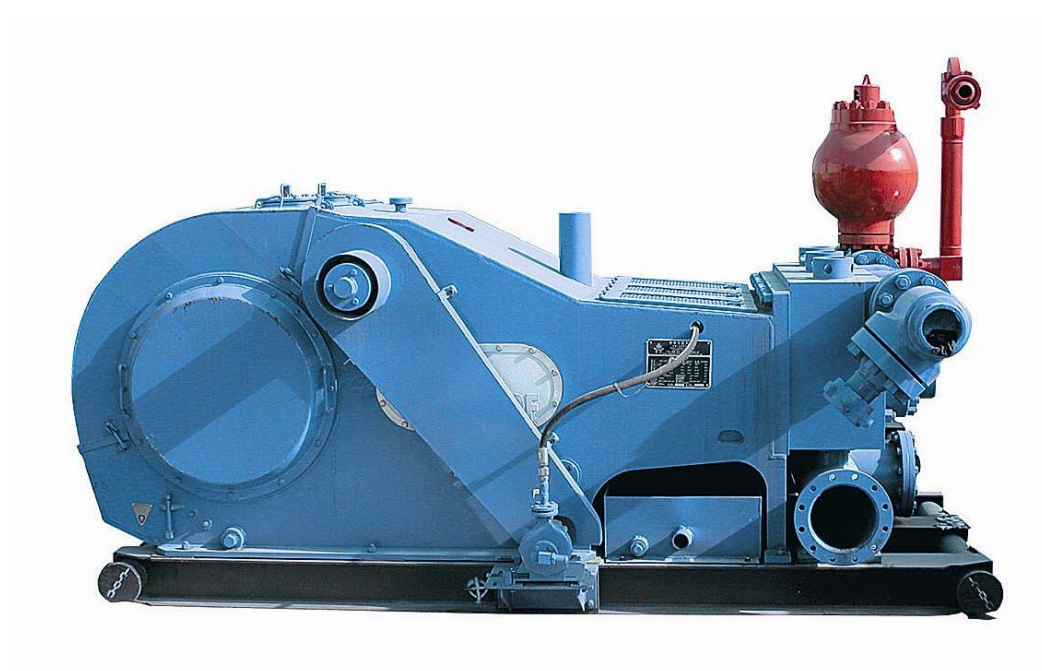

HONGHUA AMERICA, LLC

HHF-500 Mud Pump



(832) 448.8100

www.hh-america.com



Mud Pump



HHF-500 mud pump is F series, triplex single-acting piston mud pump. HHF-500 mud pump is made of high quality material, according to API 7K specification.

HONGHUA Group (HH) have provided more than 1000 sets in the world-wide. HHF series mud pump is tough and field-proven, is specifically equipped to meet almost any customer requirement. This is backed by our warranty and field support program.

Specification

▪ Rated input power	500HP (373 KW)
▪ Rated Stroke	165SPM
▪ Max. liner Di a.	6 ¾" (170 mm)
▪ Rated Stroke distance	7.5" (191 mm)
▪ Gear Ratio:	4.286: 1
▪ Suction pipe size:	8" (200 mm), Flanged
▪ Discharge pipe size:	API 4 1/16" (103mm) Flanged, 5000psi
▪ Valve chamber size:	API 5 #
▪ Lubrication:	Forced and splash
▪ Discharge flow and pressure:	please reference table 1 and table 2





Table 1: Pressure parameter for mud pump HHF-500

Diameter of Liner	6 ¾"	6 ½"	6"	5 ½"	5 "	4 "
Rated pressure (MPa-psi)	1342 psi 9.3 MPa	1447 psi 10.0 MPa	1699 psi 11.7 MPa	2020 psi 13.9 MPa	2442 psi 16.8 MPa	3820 psi 26.3 MPa

Table 2: Discharge parameter for mud pump HHF-500

Stroke (spm)	Rated power		Discharge capacity GPM					
	kW	HP	6 ¾"	6 ½"	6"	5 ½"	5 "	4 "
170	384	515	593	549	468	393	325	208
165*	373*	500*	575	533	454	382	316	202
150	339	455	523	485	413	347	287	184
140	316	424	488	452	386	324	268	171
130	294	394	453	420	358	301	249	159
120	271	364	418	388	330	278	229	147
110	249	334	383	356	303	255	210	135
1	-	-	3.49	3.23	2.75	2.31	1.91	1.22

Notes:

1. Calculated as per volumetric efficiency (100%) and mechanical efficiency (90%).
2. * shows rated stroke numbers while operating.





Dimension

- Transport dimension**

- Length** **12' (3659mm)**

- Width** **6'-5 ½" (1970mm)**

- Height** **5' -1 ½" (1562mm)**

- Weight (without damper)** **21595 lbs (9795 kg)**

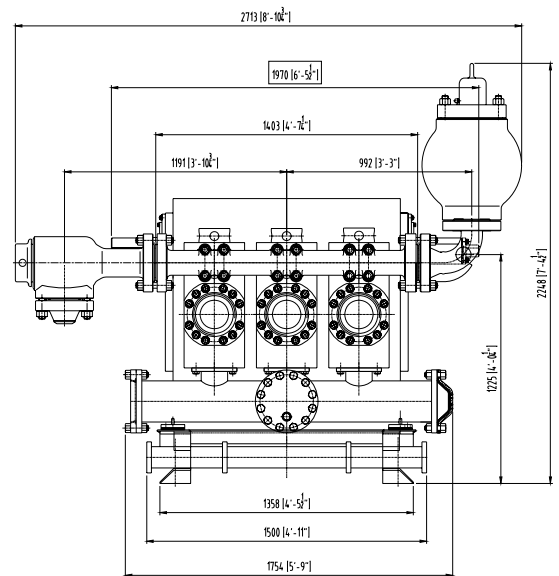
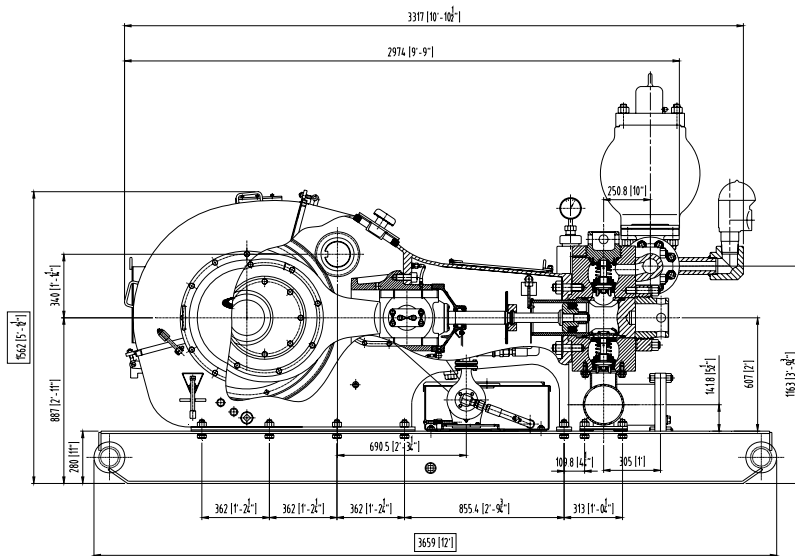



Equipment scope

- Mud pump with a liner
 - Damper and safety valve
 - Completed with spare parts and special tools and fits
-
- We also maintain spare parts for you all requirements.

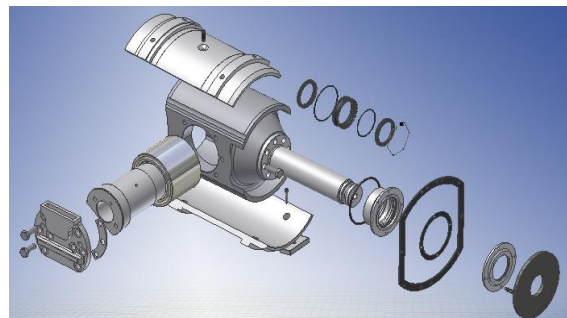

Please contact us if you need more information!

Honghua, America, LLC

8300 McHard Road, Houston, TX 77053

Tel : (832) 448.8100

Fax : (832) 448.8101

E-mail: sales@hh-america.com

Website: www.hh-america.com

